

TITLE: Pelican 1620 Transport Case Design Refinements

PRODUCTS AFFECTED: Pelican's 1620 Transport Case

INTRODUCTION: The 1620 Transport Case design has been modified (**Excluding models manufactured in Germany**).

DETAILS:

Exact revised measurements can be found at www.pelicanoem.com.

Design refinements:

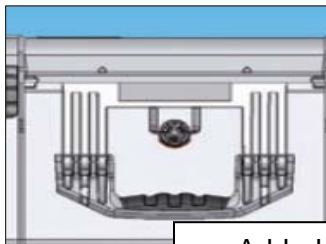

Added overmolded front and side handles

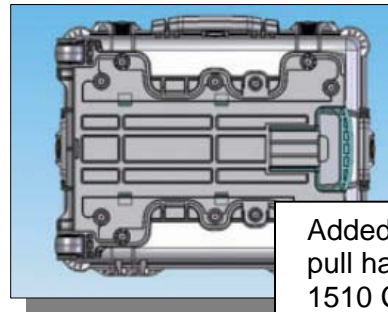
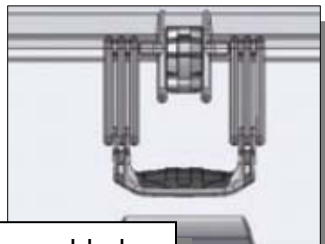

Added one-handed-action pull handle dolly (Similar to 1510 Carry On and 1560)

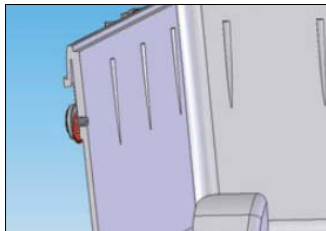

Inside wall thickness removed behind purge valve area to increase internal volume

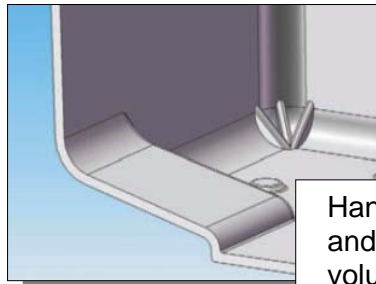

Handle recess area deepened and narrowed – less internal volume

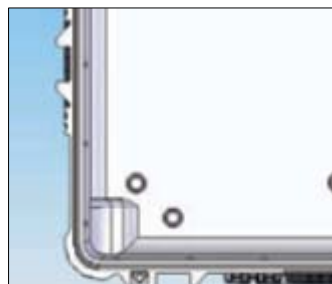

Wheel well ribs and interior flow channels removed to increase internal capacity

